



DISTRIBUTION SURGE PROTECTOR - DSP

SPIKE/SURGE PROTECTION

Description

The Sollatek DSP is available either as a single phase unit (DSP1P-0) or as a three phase unit (DSP3P-0). It is connected at the point of mains entry into the house, building or factory.

The Sollatek DSP prevents surges and transient overvoltages from filtering through the incoming mains supply and damaging sensitive electrical and electronic equipment.

The DSP will provide surge and spike protection to all equipment within. As the DSP is shunt connected and not in series, it is not current/load dependant and can therefore protect any distribution panel, making it an extremely cost effective way to protect the whole building.

The DSP employs Metal Oxide Varistor (MOV) technology to clamp the excess voltage between phases and earth to neutral to a safe level.

Applications

All electrical and electronic equipment with IEC style sockets within building.

Tips

Whilst the DSP is connected at distribution panel, there are still spikes and surges that are generated from within the building. Therefore for more valuable/sensitive appliances, additional individual protection is advisable.

LED display

The LEDs on the front of the panel indicate what level of protection is available on each of the three phases. On any phase, two LEDs illuminated indicates full protection available, one LED that partial protection is available. If no LEDs are illuminated on a phase it indicates that the protection on that phase is inoperative. In this case the unit should be returned for service as soon as possible.

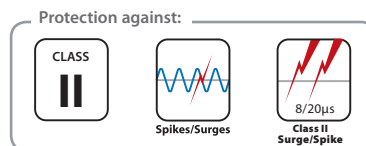

Specifications

Model	DSP1P-0	DSP3P-0
Current Rating	N/A	N/A
Phase	Single	Three
Mains Spike Protection		
Response Time (NanoSeconds)	<10	<10
Total Energy Rating (Joules)	1280J	2560J
Peak Transient Current	20kA	20kA
Maximum Let through Voltage	750V	750V
Physical		
Dims (L x W x H) (mm)	183x133x53	183x133x53
Weight Packed	500g	500g
Socket type		
	Direct wiring	Direct wiring
Packing details		
Carton QTY	40	40
Pallet QTY	480	480

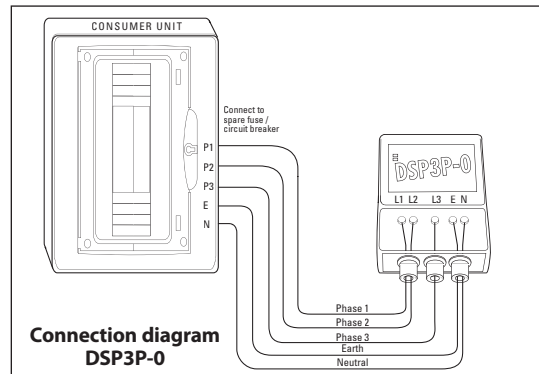
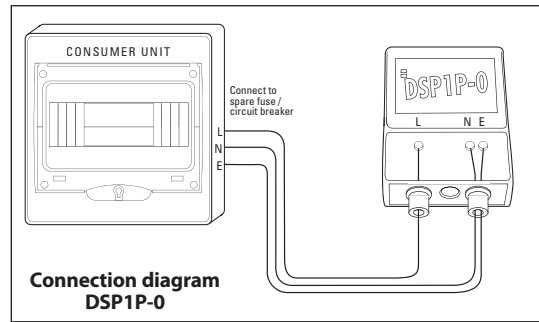

Dimensions

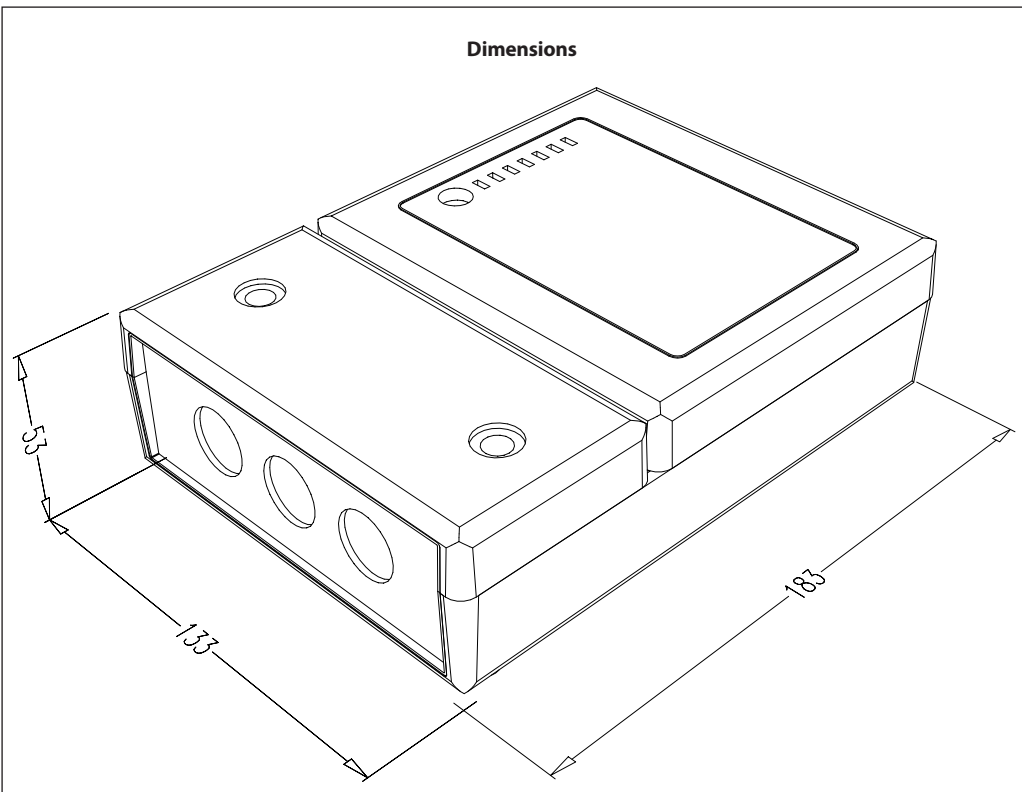

ITEM	PRODUCT CODE
DSP1P-0 SINGLE PHASE	91000200
DSP3P-0 THREE PHASE	93000200

For more information on the Sollatek's Voltage Suppressor Range refer to the **Voltage protection catalogue** or visit www.sollatek.com

Sollatek™

Sollatek (UK) Ltd.

Unit 10, Poyle 14, Newlands Drive, Poyle, Slough, SL3 0DX, UK

Tel: +44 (0)1753 688300 Fax: +44 (0)1753 685306

Technical support: support@sollatek.com Sales: sales@sollatek.com www.sollatek.com