



AVR and AUX cabinets

## AVR3AS2200-O

OUTDOOR THREE PHASE STATIC AUTOMATIC VOLTAGE REGULATOR WITH OPTIONAL AUXILIARY

### FEATURES

Designed for regions with voltage supply instability. Designed for remote operation where a high degree of reliability is essential.

Fully electronic with no moving parts for:

- High reliability
- Speed of operation
- Immunity to dust and other environmental conditions

### SUITABLE FOR

- Satellite operators
- Infrastructure telecom companies
- Embassies worldwide for reliable electrification of their posts
- Medical systems for digital imaging, scanning and x-ray equipment
- Mobile phone operators
- Offices and factories
- Grid utility companies for voltage regulation to their sub-stations
- Wind Farms

## SPECIAL FEATURES

- Wide input voltage range  $\pm 20\%$ .
- High output protection accuracy  $\pm 4\%$
- High overload capability with up to 150% for 4 minutes
- Very low losses and minimal heat dissipation due to an efficiency of over 98% at full load
- Enclosure made of galvanised steel construction with high anticorrosion paint finish
- Warranty of 2 years. Sollatek provides full backup support on all its products, with local support in over twenty countries worldwide

## EQUIPPED WITH

- Class II Surge protection
- Digital display: input and output voltage, output current
- Internal automatic bypass
- Manual bypass transferring the load to the utility grid

## OPTIONAL EXTRAS (ordered separately)

- Automatic Voltage Switcher with HVD and LVD
- Input circuit breaker
- Output circuit breaker
- Volt free contact alarms:
  - High Temp Alarm
  - Internal Bypass Status
  - I/P Circuit Breaker Status
  - LVD Alarm
  - General Fault
  - Over-Temp Alarm
  - External Bypass Status
  - O/P Circuit Breaker Status
  - HVD Alarm
- Modem for remote monitoring
- High-level lightning protection (Class I)
- Anti-condensation heaters

## TECHNICAL SPECIFICATION

<b>INPUT</b>	
Input Voltage	230/400 V $\pm 20\%$
Maximum Input Current	2666 A
Frequency Range	45 Hz to 75 Hz
Additional Voltage THD	<0.2% at input (tested at 100% linear load) (No PWM methods used)
Maximum Input THD	Can withstand >10% THD from the supply
<b>OUTPUT</b>	
Output Accuracy	230/400 V $\pm 3\%$
Maximum Output Current	2200 A
Maximum Output Power	1518 kVA
Speed of Correction	750 V/s
As the AVR powers up, the Load will receive raw mains (i.e. AVR in bypass mode) for a period of 3 seconds while the AVR initialises. If this is not desired, the AVS option (see below) can be used to delay the start-up until the AVR is initialised.	
Additional Voltage THD	<0.25% at output (tested at 100% linear load)(No PWM methods used)
Crest Factor	>1:3 permissible on load current (tested at 100% load)
Synchronisation	Output synchronised to input
Permissible Overload	1000% for 100 ms ; 150% for 4 mins ; 110% for 10 mins
Load Types	Designed to run lighting, motors, battery chargers, communications equipment, office equipment, SMPS, air- conditioners, compressors, industrial machines, medical equipment and others. Suitable for all domestic, commercial and industrial sites.
<b>GENERAL</b>	
Technology	All solid state (static) switching
Efficiency	>98% (at 100% linear load)
Heat Dissipation	4.2 kW at 216 kVA at regulation extremes ( $\pm 20\%$ )
Control	Microcontroller based control system provides self-checks, system integrity monitoring and diagnostic indicators
Control Protection	Internal surge arrestors and filters in control circuit protect against disturbances. Filtering algorithms and faulty tolerant software protect against disturbances and false measurements.
Power Connections	Supply phases, neutral and earth. Load phases, neutral and earth
Surge Protection	Heavy duty input and output surge arrestors to protect against extreme surges and lightning on the supply. Dual mode. 2880 Joules total. Class II, 8/20us, 80kA.
Digital Meters	Accurate measurement of the AC RMS currents in three-phase systems Accuracy: 0.5% + 1 digit
Internal Bypass	If the AVR enters into bypass mode for whatever reason, the input voltage will be supplied to the load without stabilisation. Before returning to normal operation (stabilising the voltage), the AVR will monitor the voltage for 3 minutes to ensure the cause has subsided.



GSM Modem	To allow remote monitoring (activation required)
Ambient Temperature	-10°C to +55°C
Relative Humidity	>95%, non-condensing
Environmental Protection	IP44
Acoustic Noise	<45 dB (A), <65 dB with fans on
Expected Service Life	>25 years
Standards	Manufactured to comply with: ISO9001:2015, CE, EN 55022:2010, EN 61000-4-2:2009, EN 61000-4-3:2006, EN 61000-4-4:2012, EN 61000-4-5:2014, EN 61000-4-6:2014, EN 61000-4-11:2004.
Dimensions (W x D X H)	Refer to Drawing
Weight	AVR Cabinet: Approx. 1800 kg per cabinet (5400 kg total) : AUX Cabinet: Approx. 880 kg
<b>OPTIONS</b> (ordered separately)	
Automatic Voltage Switcher	Automatic Voltage Switcher (AVS) provides over and under-voltage protection and a reconnect delay (configurable). Protects the load from an extreme supply voltage where the AVR might not be able to stabilise the output voltage to its operating range.
Input circuit breaker	Input circuit breaker to protect the AVR against overload and short circuits.
Output circuit breaker	Output circuit breaker to protect against overload and short circuit.
Manual By-Pass	By-pass to run load direct from utility power
DSP	Extra level of spike protection
Volt free Contact Alarms	A general alarm interface using volt free contacts are available for connection to customer site monitoring equipment (SCADA)
Anti-Condensation Heaters	Recommended when the AVR is to be installed in potential condensing environments where the AVR will be off for periods of time



**AVR CIRCUIT DIAGRAM**

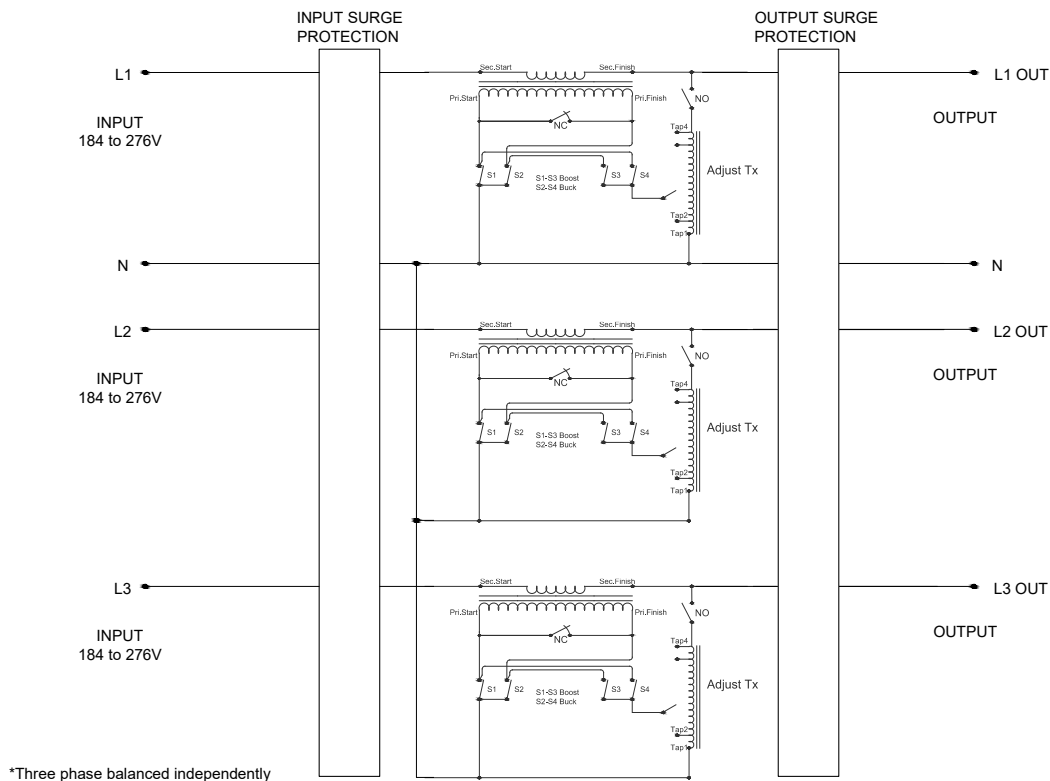

## GENERAL ARRANGEMENT DRAWING

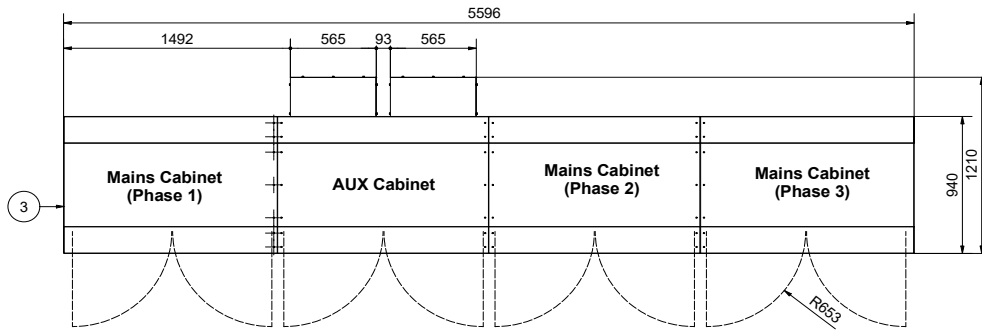

Top View - AVR Cabinet Enclosure

PARTS LIST	
ITEM	DESCRIPTION
1	AUX Cabinet Assembly
2	AVR Cabinet Assembly - AVR Phase #1
3	AVR Cabinet Assembly - AVR Phase #2
4	AVR Cabinet Assembly - AVR Phase #3
5	External Hat / Rain Canopy - Left
6	External Hat / Rain Canopy - Middle
7	External Hat / Rain Canopy - Right
8	Cabinet Plinth - Front + Rear
9	Cabinet Plinth - Side
10	Display Panel With LCD Meters
11	Incoming Isolator Switch
12	AVR Bypass Switch
13	Terminal Box - Customer's Cable Entry
14	Aluminium Gland Plate - Customer Cable
15	Air Intake Louvre
16	Key Switch Two-Position 1P 20A

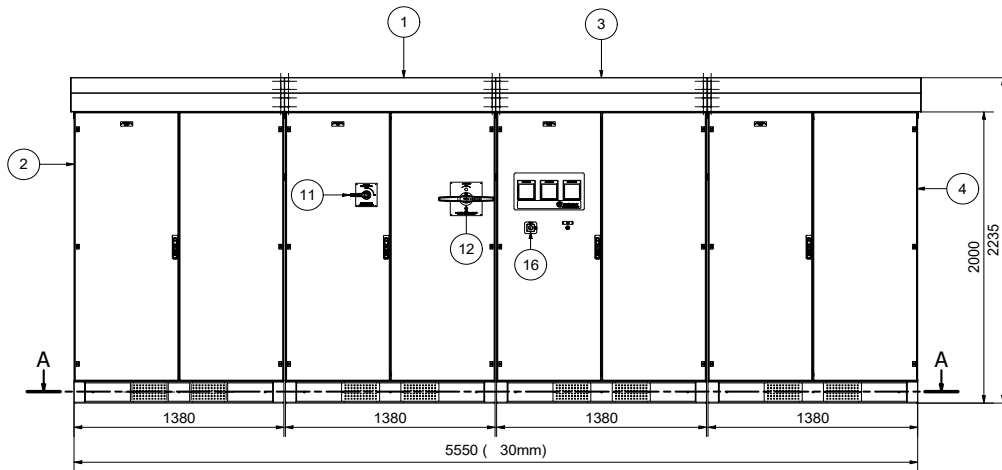

Front View - AVR Cabinet Enclosure

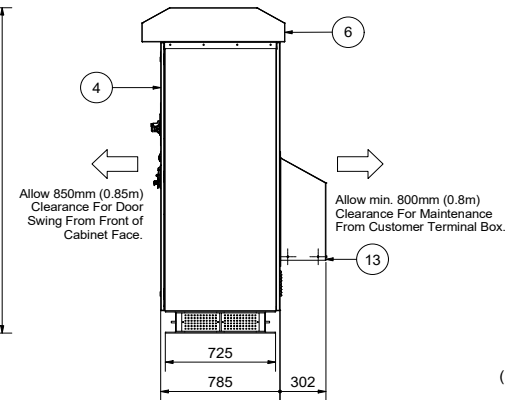

Side View (Right)  
AVR Cabinet Enclosure

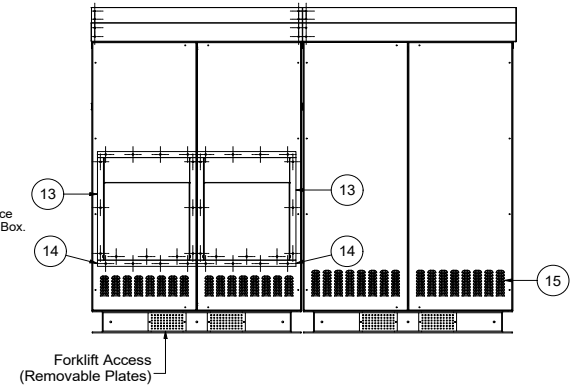

Rear View (Right) - AUX and one AVR Cabinet Enclosure

### SOLLATEK (UK) LIMITED

Sollatek House, Waterside  
Drive, Langley, Slough SL3 6EZ,  
United Kingdom

Tel: +44 (1753) 214 500  
Email: [sales@sollatek.com](mailto:sales@sollatek.com)  
Web: [www.sollatek.com](http://www.sollatek.com)

ISO9001: 2015 accredited company  
All weights and dimensions are  
approximate. Specifications are subject  
to change without prior notice. ©Sollatek  
(UK) Limited 2023. All Rights Reserved.  
SOLLATEK and the SOLLATEK device are  
the trade marks of the Sollatek group of  
companies.

